

DRUM COVER INSTALLATION & MAINTENANCE

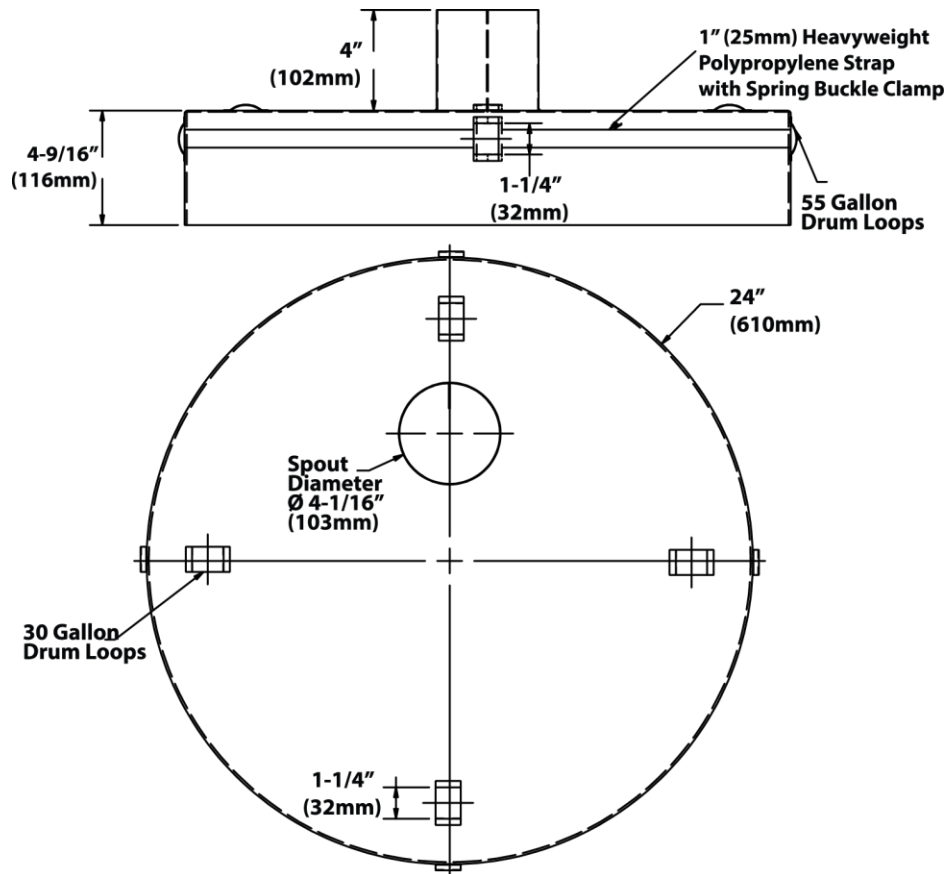

DRUM COVER

The Model 6850 Drum Cover is a fabric cover designed to allow air to escape while containing material conveyed by EXAIR's Line Vac, Air Amplifier or Adjustable E-Vac. The Drum Cover fits securely over a 55-gallon or 30-gallon open top drum with rolled a lip. A strap secures the Drum Cover to the top of the drum.

INSTALLING THE DRUM COVER

Place the Drum Cover over the drum pulling the elastic band and belt loops down below the lip of the drum. Thread strap through appropriate belt loops for size of drum being used. Secure the cinch strap tightly. **Ensure that no folds or pleats form in the Drum Cover as the cinch strap is pulled tightly. Once air is supplied to the EXAIR product these folds can cause the cinch strap to lose its grip.**

The innermost belt loops are designed for 30-gallon open top drums (20" (508mm) in diameter). The belt loops below the seams are designed for 55-gallon open top drums (24" (610mm) in diameter).

If using on non-standard drums, it is recommended that the strap be pulled tight and tested with air before conveying material to ensure the strap will hold.

Push the conveyance hose through the spout at least 2" past the bottom of the spout. Secure with a hose clamp appropriate for the conveyance hose. Do not push the hose to the bottom of the drum. If possible attach the conveyance hose to a wall or support, so that the exit of the conveyance hose points toward the bottom of the drum.

CLEANING

A dirty Drum Cover can cause back pressure on the conveyance system resulting in reduced performance. The Drum Cover should be removed and shaken over a waste container to remove bulk particulate. The Drum Cover can be washed in a manner suitable for delicate fabrics.

If routine cleaning does not solve your performance problems, please contact:

EPUTEC Drucklufttechnik GmbH

Haidenbucherstr. 1

86916 Kaufering

Phone: +49 8191 91 51 19 0

Fax: +49 8191 91 51 19 91

Email: info@eputec.de

Website: www.eputec.de

