

SPIDER 50 - SPIDER 75 SAFETY BELT SANDER FOR LATHES

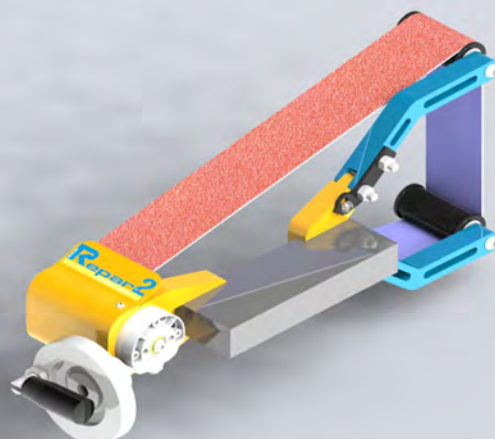
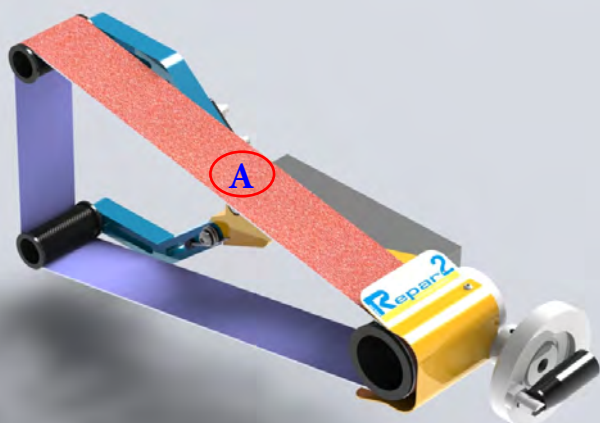
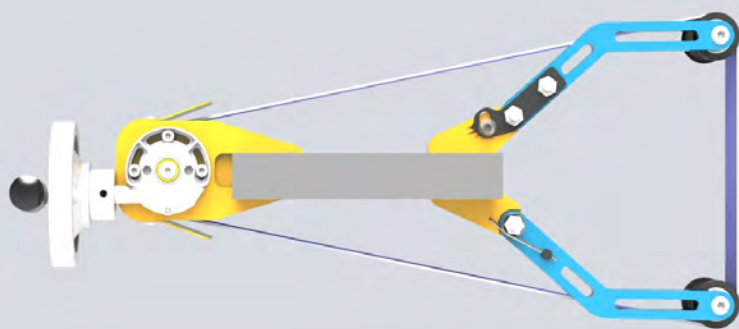
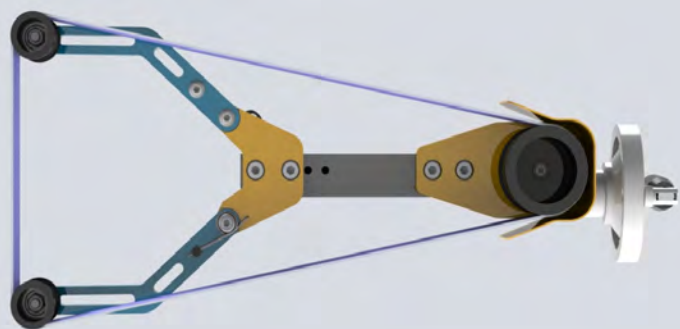

An interesting tool for sanding and finishing parts easily and safely on conventional lathes. Conceived in accordance with ISO23125 Standards 6.2.1 (no use of hands during working operations). No more need to make by hand dangerous sanding operations with risk of serious accidents. Simple fitting of the tool on the lathe turret body. Easy sanding of bars of different diameters and shapes owing to the tool conception and the tensions springs. The sanding belt is rotated easily by means of knurled cylinders in order to guarantee the best working conditions.

Available in two sizes:

SPIDER 50 - A = 900x50mm Max. ϕ 150mm

SPIDER 75 - A = 1100x75mm Max. ϕ 250mm

Supplied with 3 standard sand belts (roughness 80 - 120 - 220)

www.repar2.com

Repar2

Via Ambrogio Colombo, 176 21055 Gorla Minore (VA) Italy

Tel. +39 0331 465727 Fax: +39 0331 465728 e-mail: info@repar2.com

Export Dept: +39 02 33103673 e-mail: info@eig-group.it

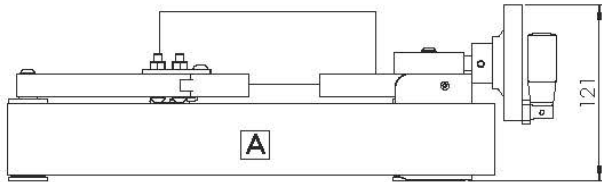
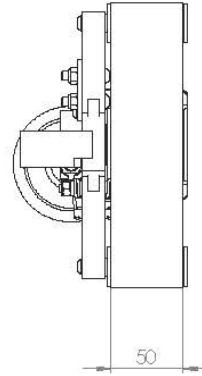
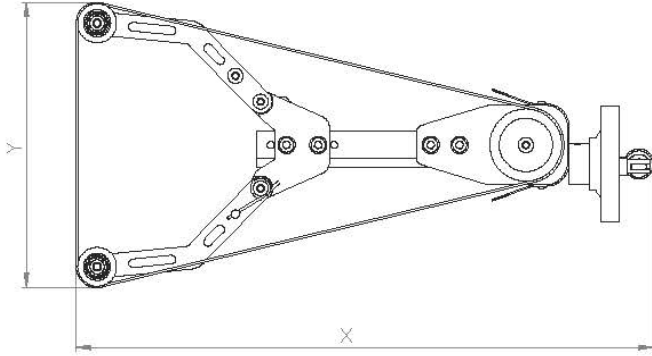

SPIDER 50

	MIN OPENING	MID OPENING	MAX OPENING
X [mm]	417	400	381
Y [mm]	171	197	227

BELT [A] :

LENGTH: 900 mm
 WIDTH: 50 mm



robust
 Stärke



stable
 Stabilität



ergonomic
 Ergonomie



long lasting
 Dauerhaftigkeit

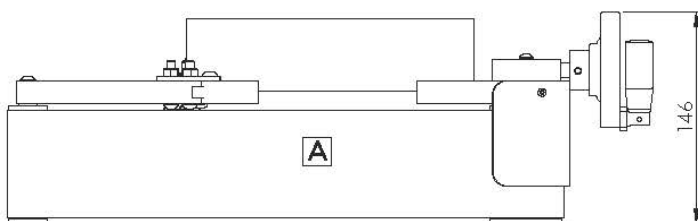
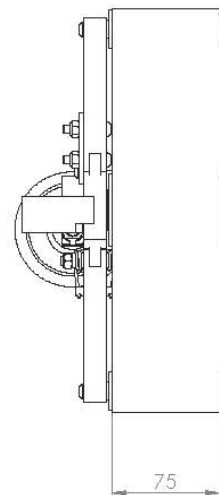
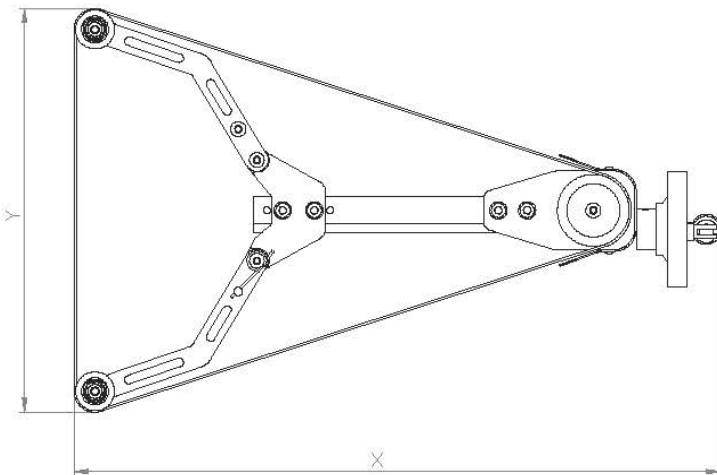

SPIDER 75

	MIN OPENING	MID OPENING	MAX OPENING
X [mm]	472	450	408
Y [mm]	246	280	336

BELT [A] :

LENGTH: 1100 mm
 WIDTH: 75 mm